

DECKING DUOFUSE ENG 03-2013



## ADVANTAGES

- Will not rot, swell, splinter or split.
- Easy to clean and to install.
- Environmentally friendly.
- Slip resistant, brushed surface.
- Minimal discolouration, maintains original look.

## INSTALLATION

The decking is mounted on support beams, that need to be fixed in the foundation, and the fixing is with specially designed clips to avoid visible fixing. Do not leave more than 50cm between the beams and please ensure that the following expansion gaps are used: 5mm in width, 5mm per meter in length and 15mm between a board and a wall.

(For further installation details, please refer to our installation guide).

## MAINTENANCE

Special cleaning products are not necessary. For normal maintenance a high pressure cleaner can be used (max. 80 bar) or just use normal domestic detergents. For persistent dirt, use a diluted bleach solution. Do not use solvents!

## COLOUR SATURATION



(stabilises after 6 to 8 weeks)

For more information, technical details, warranty terms & conditions and installation details, see,

[www.duofuse.com](http://www.duofuse.com)

## Discover the complete Duofuse® wood composite garden products



### SLAT WALL SYSTEM

A unique fencing system that combines design with durability.



### RANCH FENCING

The modular and durable alternative to hardwood or concrete ranch fencing.



### TONGUE AND GROOVE BOARDS SYSTEM

The durable and modular alternative to hardwood garden fences.

# WOOD COMPOSITE DECKING

### Produced by PLASTIVAN

PLASTIVAN NV (Belgium)  
Wantestraat 3 - B-8780 Oostrozebeke  
T +32 56 66 75 51 - F +32 56 66 91 18  
info@plastivan.com - www.plastivan.com

PLASTIVAN LTD (United Kingdom)  
Unit 4 Bonville Industrial Estate Bonville Road  
Brislington - Bristol BS4 5QU  
T 0117 300 5625 - F 0117 971 5028  
sales@plastivan.co.uk - www.plastivan.co.uk



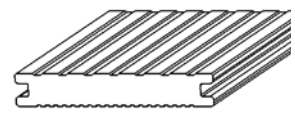
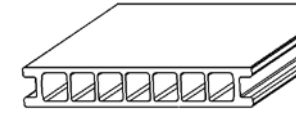
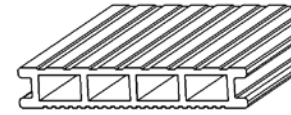
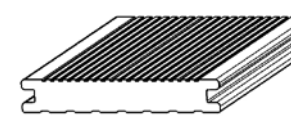
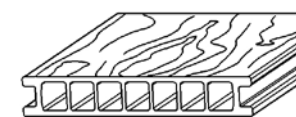
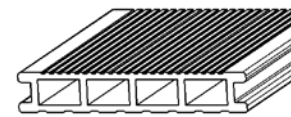

hollow board DFD 162\*

hollow board DFDE 162\*\*

full board DFD 140\*

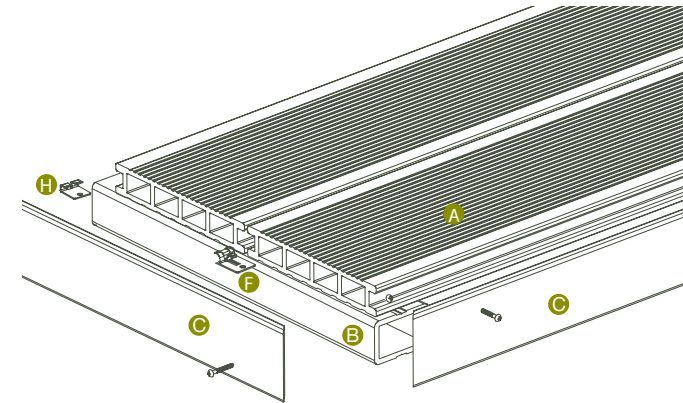
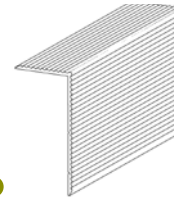
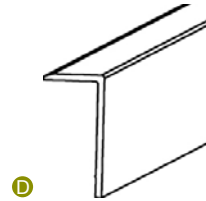
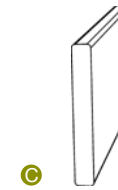
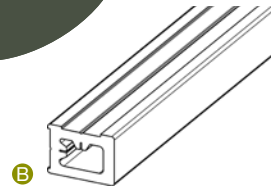

## DECKING IN WOOD COMPOSITE

### THE PERFECT COMBINATION OF WOOD AND PLASTIC

Duofuse® decking is made out of wood composite. A mix of wood flour and plastic, this means the warmth and look of solid wood combined with the unique properties of plastic.



#### PART NUMBER

#### COLOUR

#### MATERIAL

#### DIMENSIONS (WXH)

	Graphite Black	Stone Grey	Tropical Brown	Natural Brown		
hollow board DFD 162* <b>A</b>					Wood Flour and PVC	162 x 28 mm
hollow board DFDE 162** <b>A</b>					Wood Flour and PVC	162 x 28 mm
full board DFD 140* <b>A</b>					Wood Flour and PVC	140 x 23 mm
beam DFB048 <b>B</b>					Wood Flour and PVC	48,5 x 35 mm
skirting DFS076 <b>C</b>					Wood Flour and PVC	76 x 10 mm
L profile DFL078 <b>D</b>					Wood Flour and PVC	78 x 39 mm
ALU L profile DFLA076 <b>E</b>					Anodised aluminium	76 x 37 mm
CLIPS						
	DFC001 <b>F</b> standard clip		DFC002 <b>G</b> butting clip		DFC004 <b>H</b> starter and finishing clip	

\* double-sided finish: a refined and a robust finish

\*\* double-sided finish: brushed surface and a wood grain finish

Standard length of all boards and profiles : 4 m (other dimensions on request)

10 years for all mechanical properties and resistant against all ant and insect attacks